

MACHINE REQUIREMENTS

Mini SSL/SSL/CTL/MTL Cutters

Category: Low Flow

Model	Width	GPM Range	Diameter Cutting Capacity	Comments	Other	Product Weight	Max PSI Rating
4200 "A" (Dingo/Universal for Mini Skid Steers)	42	8 to 20	2 inch	Right Angle Gear Box	PRV	469	PSI Cont./Int.: 3000/3500
4200 "B" (MT-50/Bobcat)	42	8 to 20	2 inch	Right Angle Gear Box	PRV	469	PSI Cont./Int.: 3000/3500
4800 LF	48	8 to 15	3 inch	LF = Low Flow	PRV	690	PSI Cont./Int.: 3000/3500
SD 6000 LF	60	10 to 15	3 inch	SD= Standard Duty, LF = Low Flow	PRV	840	PSI Cont./Int.: 3000/3500
6000 LF	60	10 to 15	3 inch	LF = Low Flow with Right Angle Gear Box	PRV	950	PSI Cont./Int.: 3000/3500
6600 LF	66	10 to 15	3 inch	LF = Low Flow with Right Angle Gear Box	PRV	1050	PSI Cont./Int.: 3000/3500
SD7200 LF	72	15 to 20	3 inch	SD = Standard Duty, LF = Low Flow w/Right Angle Gear Box	PRV	1000	PSI Cont./Int.: 3000/3500
7200 LF	72	15 to 20	3 inch	LF = Low Flow with Right Angle Gear Box	PRV	1168	PSI Cont./Int.: 3000/3500
7201 LF (Open Front)	72	15 to 20	3 inch	LF = Low Flow w/Right Angle Gear Box & Open Front	PRV	1186	PSI Cont./Int.: 3000/3500

Category: Standard Flow

Model	Width	GPM Range	Diameter Cutting Capacity	Comments	Other	Product Weight	Max PSI Rating
4800 STD	48	16 to 25	4 inch	STD = Standard Flow	PRV	690	PSI Cont./Int.: 3000/3500
4800 "B" ASV Skid Steer Type	48	16 to 25	4 inch	Right Angle Gear Box	PRV	690	PSI Cont./Int.: 3000/3500
4800 "C" (Dingo/Universal for Mini Skid Steers)	48	16 to 25	4 inch	Right Angle Gear Box	PRV	690	PSI Cont./Int.: 3000/3500
SD 6000	60	16 to 25	4 inch	SD = Standard Duty with Right Angle Gear Box	PRV	840	PSI Cont./Int.: 3000/3500
6000 STD	60	16 to 25	4 inch	STD = Standard Flow with Right Angle Gear Box	PRV	970	PSI Cont./Int.: 3000/3500
6600 STD	66	16 to 25	4 inch	STD = Standard Flow with Right Angle Gear Box	PRV	950	PSI Cont./Int.: 3000/3500
6601 (Open Front)	66	16 to 25	4 inch	STD = Standard Flow with Right Angle Gear Box	PRV	950	PSI Cont./Int.: 3000/3500
SD7200	72	21 to 25	4 inch	SD = Standard Entry Level Model w/Right Angle Gear Box	PRV	1000	PSI Cont./Int.: 3000/3500
7200 STD	72	21 to 25	4 inch	STD = Standard Flow with Right Angle Gear Box	PRV	1168	PSI Cont./Int.: 3000/3500
7201 STD (Open Front)	72	21 to 25	4 inch	STD = Standard Flow with Right Angle Gear Box	PRV	1220	PSI Cont./Int.: 3000/3500
Alpha HD (Drop Blades)	72	23 to 32	10 inch	Direct Drive; HD = Heavy Duty w/Piston Motor	PRV with Case Drain	2318	PSI Cont./Int.: 3000/4100
Alpha HD (Flat Blades/Hardox)	72	23 to 32	10 inch	Direct Drive; HD = Heavy Duty w/Piston Motor	PRV with Case Drain	2318	PSI Cont./Int.: 3000/4100
7800 STD	78	20 to 25	4 inch	STD = Standard Flow with Right Angle Gear Box	PRV	1280	PSI Cont./Int.: 3000/3500
7801 STD	78	20 to 25	4 inch	STD = Standard Flow with Right Angle Gear Box	PRV	1280	PSI Cont./Int.: 3000/3500
9000 STD	90	20 to 25	4 inch	STD = Standard Flow with Right Angle Gear Box	PRV	1790	PSI Cont./Int.: 3000/3500

Category: High Flow

Model	Width	GPM Range	Diameter Cutting Capacity	Comments	Other	Product Weight	Max PSI Rating
7200 HF	72	26 to 40	5 inch	HF = High Flow, Right Angle Gear Box	PRV with Case Drain	1224	PSI Cont./Int.: 3000/3500
7201 HF	72	26 to 40	5 inch	HF = High Flow, Right Angle Gear Box, Piston Pump Optional	PRV with Case Drain	1270	PSI Cont./Int.: 3000/3500
Alpha XP (Drop Blades)	72	33 to 45	10 inch	XP = Extra Performance (Blades make the difference), Direct Drive/Piston Motor	PRV with Case Drain	2318	PSI Cont./Int.: 3000/4100
Alpha XP (Flat Blades)	72	33 to 45	10 inch	XP = Extra Performance (Blades make the difference), Direct Drive & Piston Motor	PRV with Case Drain	2318	PSI Cont./Int.: 3000/4100
7800 HF	78	26 to 40	5 inch	HF = High Flow, Right Angle Gear Box	PRV with Case Drain	1340	PSI Cont./Int.: 3000/4100
7801 HF	78	26 to 40	5 inch	HF = High Flow, Right Angle Gear Box	PRV with Case Drain	1340	PSI Cont./Int.: 3000/4100
9000 HF	90	26 to 40	5 inch	HF = High Flow, Right Angle Gear Box	PRV with Case Drain	1812	PSI Cont./Int.: 3000/4100

Mini/Full Size Excavator and Backhoe Loader Cutters

Category: Low Flow

Model	Width	GPM Range	Diameter Cutting Capacity	Comments	Other	Product Weight	Max PSI Rating
4200X	42	8 to 20	3 inch	Right Angle Gear Box	PRV	690	PSI Cont./Int.: 3000/3500
42X HD	42	14 to 20	4 inch	HD = Heavy Duty, Direct Drive with Piston Motor	PRV	750	3500
4800X LF	48	8 to 15	3 inch	LF = Low flow, Right Angle Gear Box	PRV	860	PSI Cont./Int.: 3000/3500

Category: Standard Flow

Model	Width	GPM Range	Diameter Cutting Capacity	Comments	Other	Product Weight	Max PSI Rating
42X XP	42	21 to 29	5 inch	Direct Drive	PRV	750	3500
4800X STD	48	16 to 25	4 inch	STD = Standard Flow, Right Angle Gear Box	PRV	860	PSI Cont./Int.: 3000/3500
48X HD	48	17 to 29	5 inch	HD = Heavy duty, Direct Drive & Piston Motor	PRV	800	3500
60X HD (Drop Blades)	60	20 to 32	10 inch	HD = Heavy duty, Direct Drive & Piston Motor	PRV	1940	4000
60X HD (Flat Blades)	60	20 to 32	10 inch	HD = Heavy duty, Direct Drive & Piston Motor	PRV	1940	4000
72X HD (Drop Blades)	72	23 to 32	10 inch	HD = Heavy duty, Direct Drive & Piston Motor	PRV with Case Drain	2330	4000
72X HD (Flat Blades)	72	23 to 32	10 inch	HD = Heavy duty, Direct Drive & Piston Motor	PRV with Case Drain	2330	4000

Category: High Flow

Model	Width	GPM Range	Diameter Cutting Capacity	Comments	Other	Product Weight	Max PSI Rating
4800X HF	48	26 to 40	5 inch	HF = High Flow, Right Angle Gear Box	PRV	890	PSI Cont./Int.: 3000/4100
48X XP	48	30 to 37	6 inch	High Flow Unit w/Direct Drive & Piston Motor	PRV	800	4000
60X XP (Drop Blades)	60	33 to 45	10 inch	XP = Extra Performance w/Direct Drive & Piston Motor	PRV with Case Drain	1940	4000
60X XP (Flat Blades)	60	33 to 45	10 inch	XP = Extra Performance w/Direct Drive & Piston Motor	PRV with Case Drain	1940	4000
72X XP (Drop Blades)	72	33 to 45	10 inch	XP = Extra Performance w/Direct Drive & Piston Motor	PRV with Case Drain	2330	4000
72X XP (Flat Blades)	72	33 to 45	10 inch	XP = Extra Performance w/Direct Drive & Piston Motor	PRV with Case Drain	2330	4000



CUMMINGS and BRICKER INC.

www.cummingsandbricker.com
support@cummingsandbricker.com



Selling Points

1. Over 20 years of experience building brush cutters.
2. ASAE compliant: Hose sleeves, 3000# rated hoses, 3800# rated hydraulic motors.
3. 1/4" decks reinforced in front with 3/8"x2" "V" shaped nose angle.
4. Non-slip step for entry to skid steer.
5. Deck cannot be bent by lifting. Flux core welded bracing and flared skids for easy maneuverability.
6. Wear runners extend up the front of the deck so it can be used to clear deadfall logs.
7. Galvanized 5/16" safety chains front and rear.
8. Gearbox and motor preassembled onto a 1/2" steel plate, and then welded onto the deck. This eliminates misalignment problems.
9. Shear bolt protected at motor coupler.
10. Balanced stump jumper.
11. Welded collar on the bottom of the deck prevents weeds and wire from damaging gearbox seal.
12. Castle nut holding stump jumper and blade assembly does not extend below the stump jumper which prevents damage to threads on the shaft.
13. Counterclockwise blade rotation with high lift blades. Research shows that counterclockwise rotation provides better performance.
14. Top lock nut on blades for extra safety.
15. Built in safety cushion valve stops blades quickly when hydraulic flow is shut off.
16. Widest range of models available on the market.
17. Powder coated paint

Skid Steer models



"X" Series for excavators



100-120 LEHIGH AVE.
P.O. BOX 928
BATAVIA, NY 14021-0928
PHONE: 800-252-1552 FAX: 888-852-7406

100 STOVER DRIVE
CARLISLE, PA 17015-9782
PHONE: 800-222-8969
FAX: 717-249-9384



[Click here for ordering programs-Select Program #4 from Bookmarks](#)

Standard Duty Cutters

FOB C&B Warehouse = 42 & 48" - \$200; 60" & up \$500. Factory direct ship = Get freight quote.

ITEMNUMBER	DESCRIPTION	WEIGHT (lbs.)	PRICE
SD6000LF	Brush Cutter 60" Low Flow - Skidsteer, 10-15 GPM	970	\$6,776.00
SD6000B	Brush Cutter 60" Standard Flow - Skidsteer, 16-25 GPM	970	\$6,776.00
SD7200LF	Brush Cutter 72" Low Flow - Skidsteer, 15-20 GPM	1168	\$7,271.00
SD7200B	Brush Cutter 72" Standard Flow - Skidsteer, 21-25 GPM	1168	\$7,271.00

The standard duty cutters are designed to cut up to 2" diameter. Hoses and couplers are included. One year warranty on the structural steel.



Universal Pick-Up Plate



Blade Carrier



	SD6000LF	SD6000B	SD7200LF	SD7200B
Width	60	60	72	72
Length	61.75	61.75	73.75	73.75
Blade Carrier Type	1.000 Bar Welded to .313 Spun Formed High Strength Steel			
Blades	(2) .5000 x 4.000 (High Strength, Updraft)			
Blade Rotation	Counter Clockwise			
Cutting Capacity MAX	2"	2"	2"	2"
Motor Protection	Pressure Reliefs			
Deck Thickness	.250 One Piece of Formed Steel			
Required GPM	10 - 15	16 - 25	15 - 20	21 - 25
PSI Min/Max	3000/3500	3000/3500	3000/3500	3000/3500
Weight (lbs.)	970 lbs.	970 lbs.	1,168 lbs.	1,168 lbs.



Heavy Duty Cutters

FOB C&B Warehouse = 42 & 48" - \$200; 60" & up \$500. Factory direct ship = Get freight quote.



BEFORE



AFTER



4200 SERIES



4800 SERIES



6000 SERIES



7201 (OPEN FRONT)

Low Flow

ITEMNUMBER	DESCRIPTION	WEIGHT (lbs.)	PRICE
4200B	Brush Wolf 42" 8-20GMP, w/Toro Dingo Q-Tach	510	\$5,125.00
4200BOBCAT	Brush Wolf 42" 8-20GPM, w/ Bobcat MT50/52/55/85/100 Hookup	470	\$5,125.00
4200BSSL	Brush Wolf 42" Low Flow w/ Bobcat Universal Skid Steer Plate		\$5,125.00
4201B	Brush Wolf 42" 8-20GPM, Open Front w/Toro Dingo Q-Tach		\$5,464.00
4201BOBCAT	Brush Wolf 42" 8-20GPM, Open Front w/Bobcat MT Q-Tach		\$5,464.00
4801B	Brush Wolf 48" 16-25GPM, Open Front w/Toro Dingo Q-Tach		\$6,688.00
4801BOBCAT	Brush Wolf 48" 16-25GPM Open Front Bobcat Mt Q-Tach		\$6,688.00
4800LFASV	Brush Wolf 48" Low Flow w/ASV RC30 Hookup	725	\$6,273.00
6000LF	Brush Wolf 60" Low Flow	1000	\$7,304.00
6600LF	Brush Wolf 66" Low Flow	1020	\$7,655.00

Standard Flow

ITEMNUMBER	DESCRIPTION	WEIGHT (lbs.)	PRICE
4800B	Brush Wolf 48" Standard Flow w/Bobtach Hookup	725	\$6,273.00
6000B	Brush Wolf 60" Standard Flow	1000	\$7,304.00
6600B	Brush Wolf 66" Standard Flow	1100	\$7,655.00
6601B	Brush Wolf 66" Open Front 16-25 GPM		\$8,137.00
7200B	Brush Wolf 72" Standard Flow	1210	\$7,987.00
7201B	Brush Wolf Open Front 72" Standard Flow	1225	\$8,491.00
72HDO	Brush Wolf 72" Open Front - 8" Capacity, 23-29GPM/Case Drain Required	1550	\$13,085.00
7800B	Brush Wolf 78" Standard Flow	1308	\$8,379.00
7801B	Brush Wolf 78" Open Front - 4" Capacity, 21-25 GPM	1310	\$8,908.00
78HDO	Brush Wolf 78" Open Front - 8" Capacity, 23-29GPM/Case Drain Required	1610	\$13,396.00
9000B	Brush Wolf 90" Standard Flow	1900	\$13,004.00

High Flow

ITEMNUMBER	DESCRIPTION	WEIGHT (lbs.)	PRICE
7200HF	Brush Wolf 72" High Flow	1250	\$9,455.00
7201HF	Brush Wolf 72" Open Front High Flow	1225	\$9,960.00
72XPO	Brush Wolf 72" Open Front - 8" Capacity, 30-40GPM/Case Drain Required	1494	\$13,129.00
7800HF	Brush Wolf 78" High Flow	1400	\$9,851.00
7801HF	Brush Wolf 78" Open Front - 5" Capacity, 26-40 GPM	1310	\$10,473.00
78XPO	Brush Wolf 78" Open Front - 8" Capacity, 30-40GPM/Case Drain Required	1610	\$13,441.00
9000HF	Brush Wolf 90" High Flow	2145	\$15,197.00



Heavy Duty Cutters

MODEL	4200	4800 LF	4800	6000 LF	6000	6600LF	6600
OVERALL WIDTH	43 3/4"	49 3/4"	49 3/4"	61 3/4"		67 3/4"	
OVERALL LENGTH	58 1/4"	60"	60"	72 1/4"		78 1/4"	
BLADE CARRIER TYPE	1" Thick GRD-50 Bar			1" Thick GRD-50 Bar Welded To .313 Spun Formed GRD-50 High Strength Steel			
BLADES	1/2" X 4"				1/2" X 4"		
BLADE ROTATION	CCW						
CUTTING CAPACITY MAX.	2"	3"	4"	3"	4"	3"	4"
MOTOR PROTECTION	Pressure Relief						
DECK THICKNESS	10 GA.	7 GA.			1/4"		
REQUIRED GPM	8 - 20	8 - 15	16 - 25	10 - 15	16 - 25	10-15	16-25
OPTIMUM GPM	14	14	24	14	24	25	25

MODEL	7200LF	7200/7201B	7200/7201 HF	7800	7800 HF	9000	9000 HF
OVERALL WIDTH	73 3/4"			79 3/4"		93 1/4"	
OVERALL LENGTH	84 1/4"			90 1/4"		76 1/4"	
BLADE CARRIER TYPE	1" Thick GRD-50 Bar Welded To .313 Spun Formed GRD-50 High Strength Steel						
BLADES	1/2 X 4"				1/2 X 4"		
BLADE ROTATION	CCW				Off Set CCW		
CUTTING CAPACITY MAX.	3"	4"	6"	4"	5"	4"	5"
MOTOR PROTECTION	Pressure Reliefs						
DECK THICKNESS	1/4"						
REQUIRED GPM	15 - 20	21-25	26 - 40	20 - 25	26 - 40	20 - 25	26 - 40
OPTIMUM GPM	24		35	24	35	24	35

***7201B Open Front Brush Cutters cut through heavy brush without stopping to raise and lower the cutter.**

STANDARD FEATURES ON ALL MODELS

DRIVE PROTECTION - GR2 BOLT

PSI MIN. / MAX. - 2500/3500

FLAT FACE COUPLINGS

MOTOR / GEARBOX COUPLER - MACHINED STEEL

NYLON HOSE SLEEVES

GEARBOX SEAL GUARD

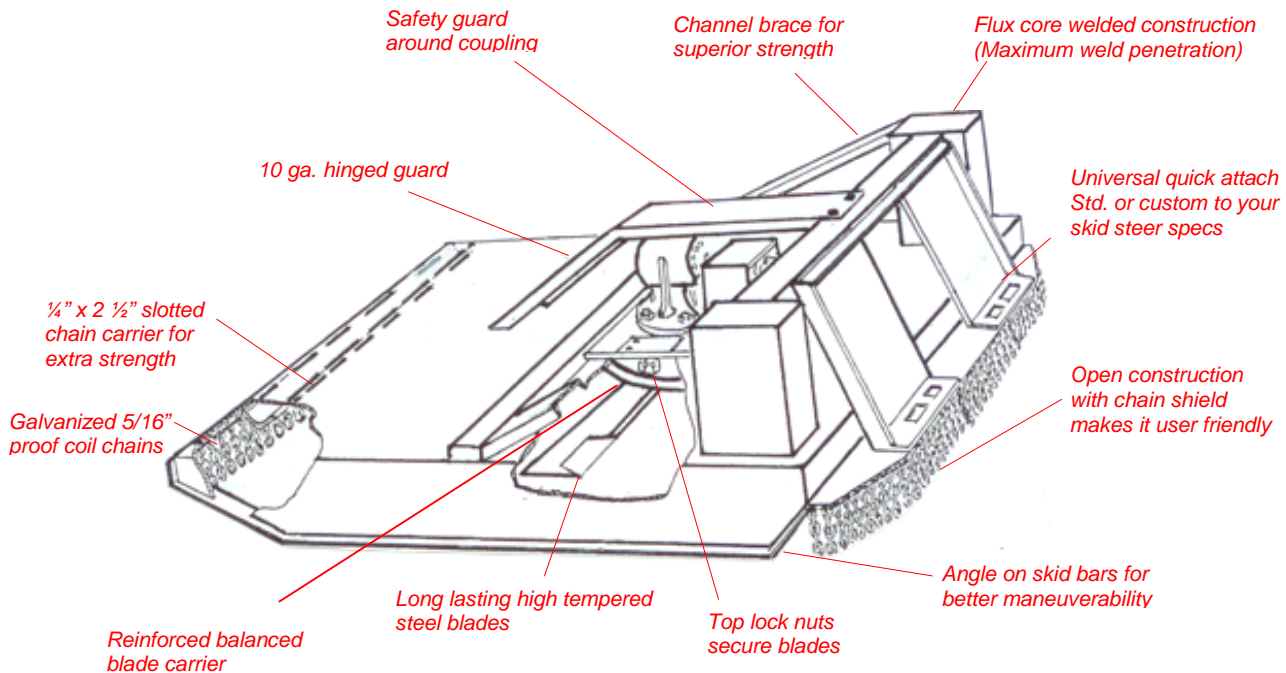



EXCAVATOR MODELS

FOB C&B Warehouse = 42 & 48" - \$200; 60" & up \$500. Factory direct ship = Get freight quote.

***90" hoses and 1/2" flat face couplers included**

"X" Series cutters are designed for excavators.

4200X and 4800X for mini excavators, 6000X and 6600X for larger machines.

Prices do not include the hanger bracket to attach the cutter to the excavator. Hanger bracket prices vary depending on the excavator model.

When sizing an "X" series cutter it's important to know the flow and pressure available at the "stick"(end of the boom). This flow rate is often different than the overall flow rate shown for the whole machine. Factory guidance on model selection is recommended.



MODEL	3600X	4200X	4800X	4800XHF	4800XLF
OVERALL WIDTH	39"	45"	51"	51"	51"
OVERALL LENGTH	20"	57"	63"	63"	63"
BLADE CARRIER	Two 1/2" steel discs	1" Thick GRD-50 Steel Disc High Strength Steel			
BLADES	Hardox 500 non-updraft	1/2" X 4"	1/2" X 4"	1/2" X 4"	1/2" X 4"
BLADE ROTATION	CCW	CCW	CCW	CCW	CCW
MAX. CUTTING	3"	3"	4"	5"	3"
DECK THICKNESS	10 GA.	10 GA.	7 GA.	7 GA.	
REQUIRED GPM	8-20	8 - 20	16 - 25	26-40	8-15
OPTIMUM GPM	14	14	24	35	14
PSI MIN/MAX	3000-3500	3000/3500	3000/3500	3000/4100	3000/3500
WEIGHT (LBS.) (approx.)	550	690	880	968	880
MOTOR PROTECTION	Pressure Reliefs				

MODEL	42X	48X	60XHD	60XP	72XHD	72XXP
POWER UNIT	Mini Excavator/ Backhoe	Mini Excavator/ Backhoe	Excavator/ Backhoe	Excavator/ Backhoe	Excavator/ Backhoe	Excavator/ Backhoe
OVERALL WIDTH	53"	55 1/2"	72 1/4"	72 1/4"	82"	87"
OVERALL LENGTH	57"	63"	74 1/2"	74 1/2"	87"	87"
CUTTING WIDTH	42"	48"	60"	60"	72"	72"
BLADE CARRIER	1" Disc, High Strength Steel		1" Disc, High Strength Steel		1" Thick GRD-50 Bar Welded To .313 Spun Formed GRD-50 High	
BLADES	(2) 1/2" X 4"		(3) 5/8" X 5" Drop Blades (4) Flat Blades Optional		(3) 5/8" X 5" Drop Blades (4) Flat Blades Optional	
BLADE ROTATION	CCW	CCW	CCW	CCW	CCW	CCW
MAX. CUTTING	4"	5"	10"	10"	10"	10"
DECK THICKNESS	10 GA.	7 GA.	3 GA.	3 GA	3 GA	3 GA
REQUIRED GPM	14 - 23	17 - 29	20-32	33-45	20-32	33-45
DRIVE PROTECTION	Pressure Reliefs		Pressure Reliefs, Case Drain		Pressure Reliefs, Case Drain	



EXCAVATOR MODELS

ITEMNUMBER	DESCRIPTION	WEIGHT (lbs.)	PRICE
3600X	Brush Wolf 36" Mini Ex-Low Flow (Price Hanger Bracket Separately)	550	\$6,072.00
4200X	Brush Wolf 42" Mini Ex-Low Flow (Price Hanger Bracket Separately)	690	\$6,505.00
4800X	Brush Wolf 48" Mini Ex-Standard Flow (Price Hanger Bracket Separately)	770	\$7,159.00
4800XHF	Brush Wolf 48" Mini Ex-High Flow (Price Hanger Bracket Separately)	770	\$8,432.00
4800XLF	Brush Wolf 48" Mini Ex-Low Flow (Price Hanger Bracket Separately)	770	\$7,159.00
42XHDD	42" Rotary Cutter - Direct Drive-Piston Motor, 14-23 GPM - Add Hanger	710	\$10,325.00
48XHDD	48" Rotary Cutter - Direct Drive-Piston Motor, 17-29 GPM - Add Hanger	806	\$10,744.00
60XHDD	60" Rotary Cutter - Drop Blades, Direct Drive-Piston Motor, 20-32 GPM - Add Hanger	1300	\$14,295.00
60XHDFB	60" Rotary Cutter - Flat Blades, Direct Drive-Piston Motor, 20-32 GPM - Add Hanger		\$17,179.00
60XXP	60" Rotary Cutter - Drop Blades, Direct Drive-Piston Motor, 33-45 GPM - Add Hanger	1300	\$14,645.00
60XXPFB	60" Rotary Cutter - Flat Blades, Direct Drive-Piston Motor, 33-45 GPM - Add Hanger		\$17,529.00
72XHDD	72" Rotary Cutter - Drop Blades, Direct Drive-Piston Motor, 23-32 GPM - Add Hanger	1700	\$16,260.00
72XHDFB	72" Rotary Cutter - Flat Blades, Direct Drive-Piston Motor, 20-32 GPM - Add Hanger	1900	\$19,160.00
72XXP	72" Rotary Cutter - Drop Blades, Direct Drive-Piston Motor, 33-45 GPM - Add Hanger	1700	\$16,260.00
72XXPFB	72" Rotary Cutter - Flat Blades, Direct Drive-Piston Motor, 33-45 GPM - Add Hanger	1900	\$19,160.00

CHAIN GUARDS

ITEMNUMBER	DESCRIPTION	WEIGHT (lbs.)	PRICE
16479	Chain Curtain Guard - For 42X, Order 1 Or 2	36	\$520.00
16549	Chain Guard - 48X, Order 1 Or 2	45	\$580.00
16578	Chain Curtain Guard - For 60X Order 1 Or 2	64	\$768.00
16624	Chain Curtain Guard - For 72X, Order 1 Or 2	79	\$900.00

COMPLETE HANGER MOUNTING PLATES

For 4200X Models

ITEMNUMBER	DESCRIPTION	PRICE
XBOBCATXCHAN GES	X Mount Hanger - 16556 Plate Bobcat XChange System	\$1,668.00
XJD35S	X Mount Hanger - 16556 Plate JD 27/35/110TLB	\$1,652.00
XJD50QS	X Mount Hanger - 16556 Plate JD 50/60 Q-Tach	\$1,652.00
XKUBOTAKX040S	X Mount Hanger - 16556 Plate Kubota KX040/71/91/121/U35	\$1,652.00
XKUBOTAKX057S	X Mount Hanger - 16556 Plate Kubota KX057/191/U55	\$1,652.00

For 42X / 48X / 4800X Models

ITEMNUMBER	DESCRIPTION	PRICE
XBOBCATXCHAN GEL	X Mount Hanger - 16557 Plate Bobcat XChange System	\$1,683.00
XJD50QL	X Mount Hanger - 16557 Plate JD 50/60Q	\$1,667.00
XKUBOTAKX040L	X Mount Hanger - 16557 Plate Kubota KX040/71/91/121/U35	\$1,667.00
XKUBOTAKX057L	X Mount Hanger - 16557 Plate Kubota KX057/191/U55	\$1,667.00

***Inquire on complete hanger and mounting options not listed above.**



HANGER MOUNTING PLATES

HOW TO PRICE AN X CUTTER: **1.** Choose Cutter **2.** Choose Mounting Plate (or blank mount) **3.** Choose Hanger Mounting **4.** Choose Pins (if needed)

****Add the required hanger brackets (ears) which vary in price depending on brush cutter and excavator models. Quotes provided on request. Blank hanger plates are available if you choose to outsource your hanger bracket.****

ITEMNUMBER	DESCRIPTION	PRICE
16556	Hanger Plate - Welded, Painted **Add Hanger For 4200X**	\$881.00
16557	Hanger Plate - Welded, Painted **Add Hanger For 42X/48X/4800X**	\$932.00
16558	Hanger Plate - Welded, Painted **Add Hanger For 60X/72X/6000X/6600X**	\$1,352.00

X MOUNT HANGER PINS

ITEMNUMBER	DESCRIPTION	PRICE
XPINS40	X Mount Hanger Pin Set 40MM	\$509.00
XPINS45	X Mount Hanger Pin Set 45MM	\$679.00
XPINS50	X Mount Hanger Pin Set 50MM	\$780.00
XPINS55	X Mount Hanger Pin Set 55MM	\$853.00
XPINS60	X Mount Hanger Pin Set 60MM	\$855.00
XPINS65	X Mount Hanger Pin Set 65MM	\$1,076.00
XPINS70	X Mount Hanger Pin Set 70MM	\$1,249.00
XPIN80	X Mount Hanger Pin Set 80MM	\$547.00

REPLACEMENT BLADE KITS



ITEMNUMBER	DESCRIPTION	PRICE
15265K	14-3/4" Blade/Hardware Kit - For 4200/4800/42X/4200X/4800X/9000 Models	\$210.00
15265K9	14-3/4" Blade/Hardware Kit - For 9000 Models	\$401.00
16631K	17-3/4" Blade/Hardware Kit - For 48X Models	\$228.00
15267K	22" Blade/Hardware Kit - For 6000 Models	\$253.00
15268K	24" Blade/Hardware Kit - For 6600 Models	\$256.00
15269K	28" Blade/Hardware Kit - For 7200 Models	\$308.00
16186K	28" Blade/Hardware Kit - For 7201 Models (No Lift Blades)	\$308.00
15270K	31" Blade/Hardware Kit - For 7800 Models	\$288.00
15272K	18" Blade/Hardware Kit - For Alpha/60X/72X/72MAX Models - 3 Blade	\$446.00
15273K	4 Flat Blade/Hardware Kit - For Alphafb/60XFB/72XFB/72MAXFB Models	\$1,829.00